

Data sheet: CHP series 55 – 90 kW (el)

A CHP unit in a completely new design, designed for the performance classes 55 – 90 kWel. The new CHP series delivers exhaust gas values below the new legal limit values (< 250 NOx) and thus actively contributes to climate protection.

The specially developed control intelligence combines powerful engine management from the automotive sector with powerful CHP control. Engine management for cars enables not only an absolutely new emission and performance optimized style, but also operating modes and response times to power and gas changes, previously reserved only for the automotive industry. Thanks to its compact and small design, this CHP can be installed through any standard door of only 86 cm width.

Standard components WWK:

- Steel silencer designed for 45 dB(A) under 10m free field condition
- Silencer in stainless steel design at extra cost
- Heating component with integrated return lift without heating circuit pump
- Exhaust gas heat exchanger (220°C) in stainless steel design 1.4571
- Touch display incl. PC integrated in the control cabinet
- Oxidation catalyst
- Pump for aftercooling

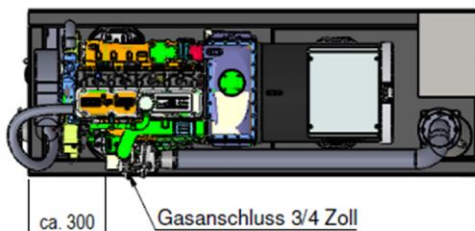
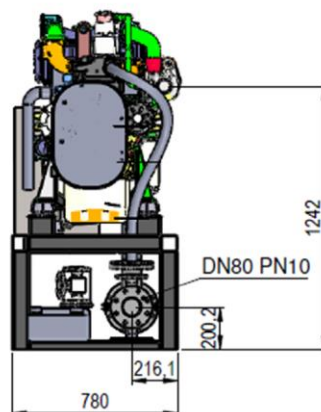
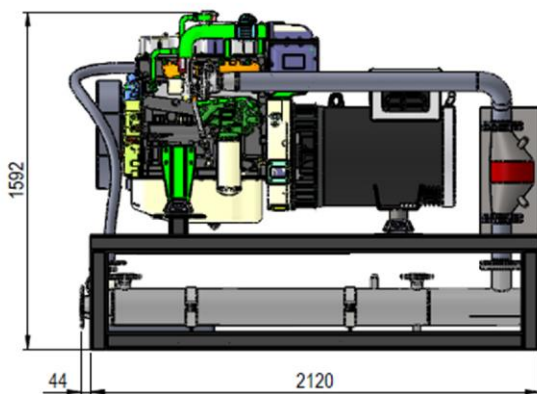

Wasserflansche DN40PN10
Notkühler
Heizung
Gasanschluss

