

JAVAC

Owner's Operating Manual

**Models
SIR-5T**

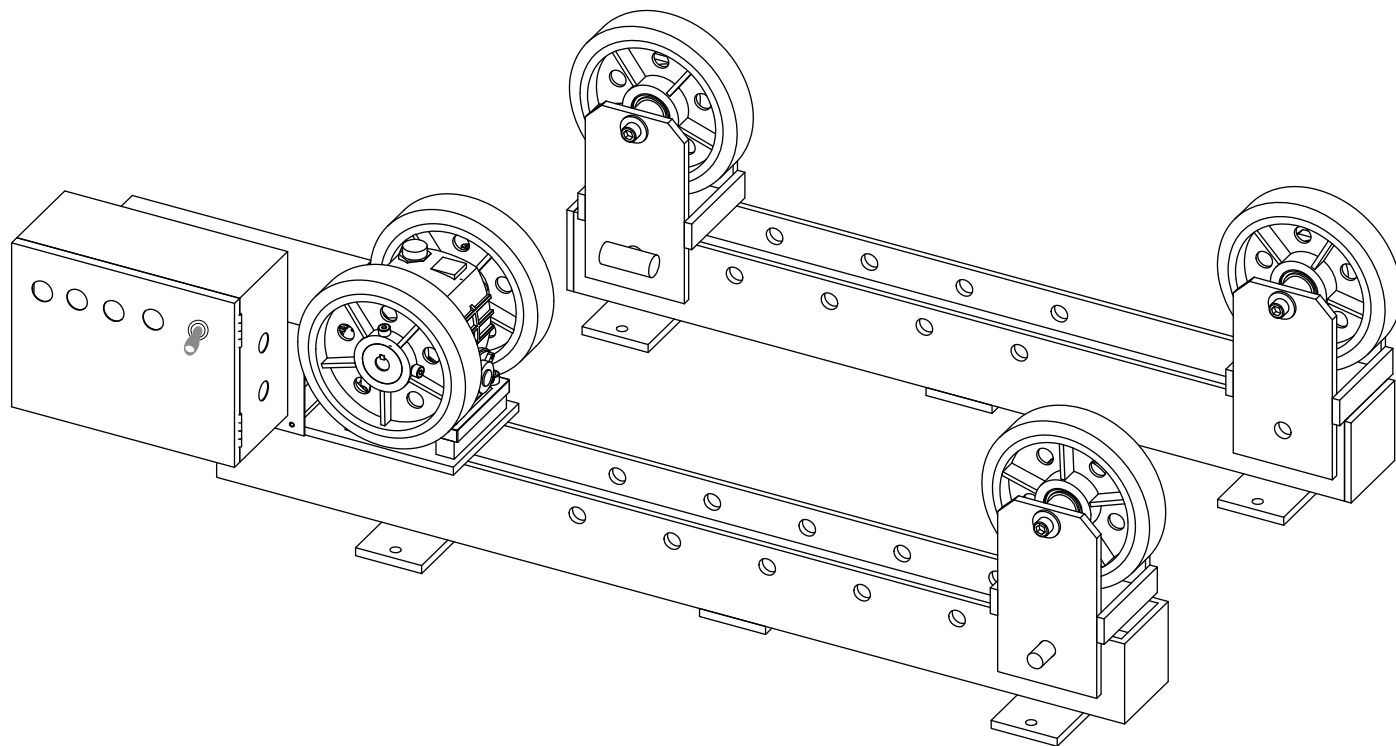

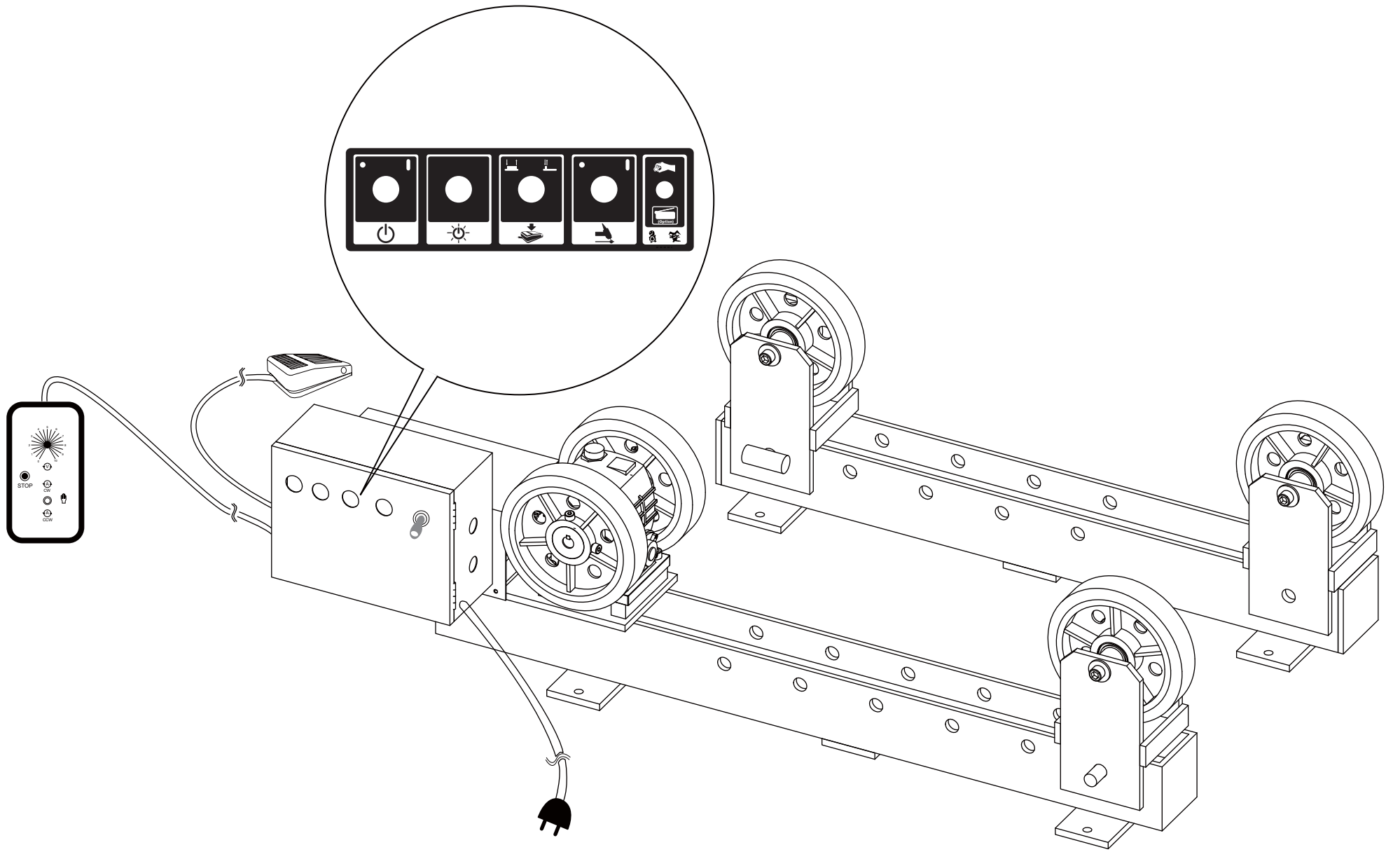

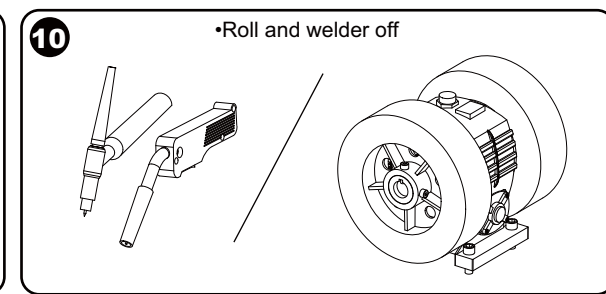
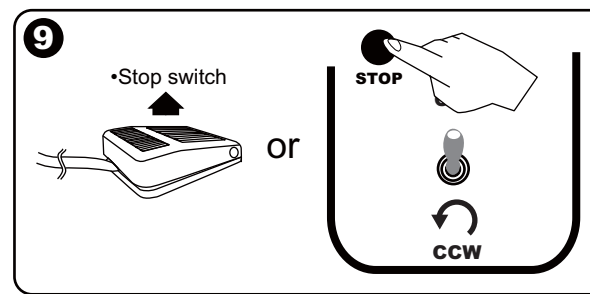
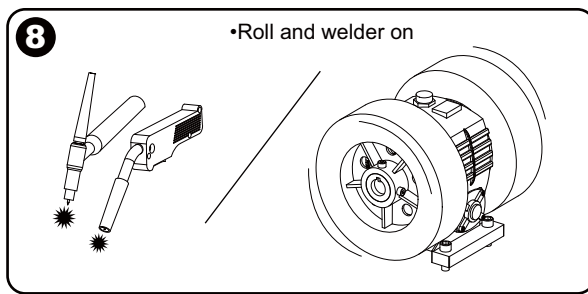
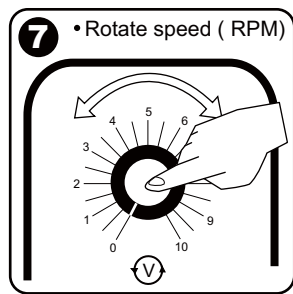
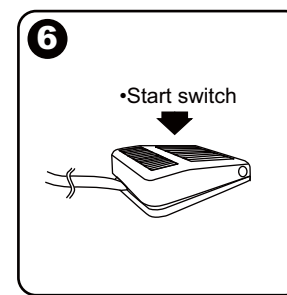
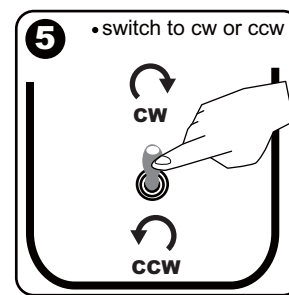
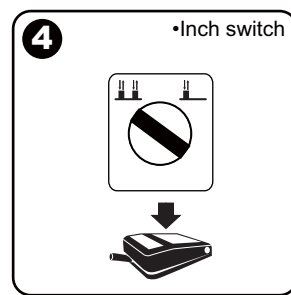
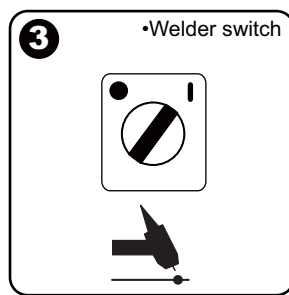
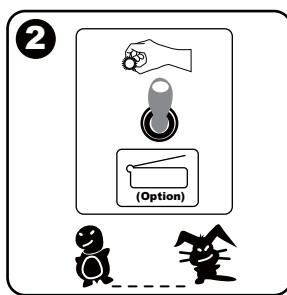
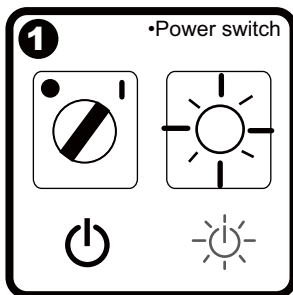
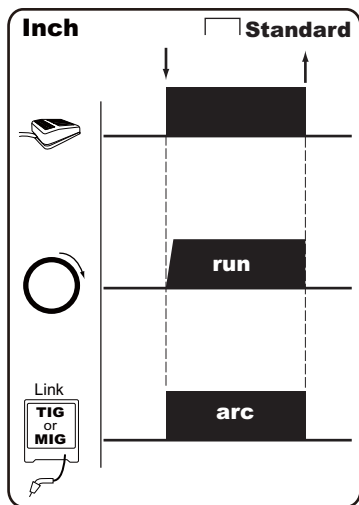

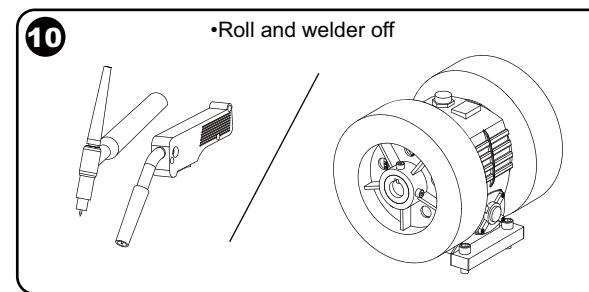
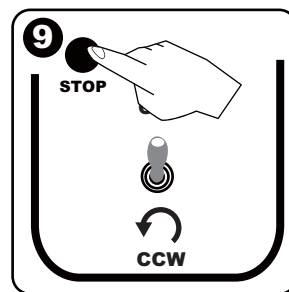
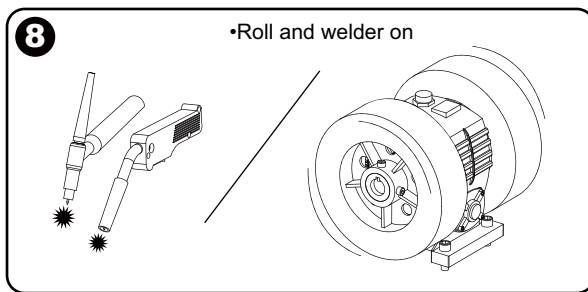
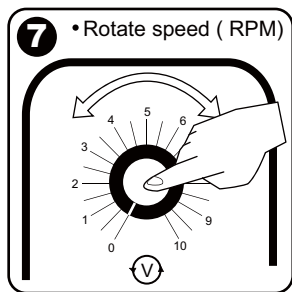
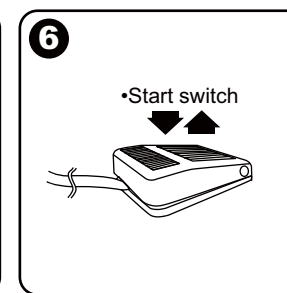
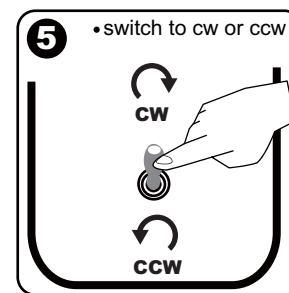
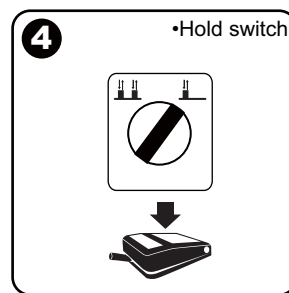
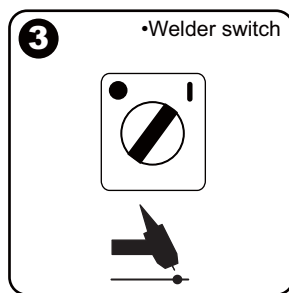
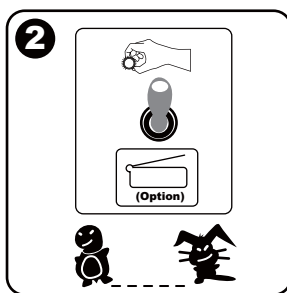
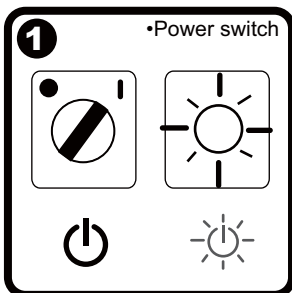
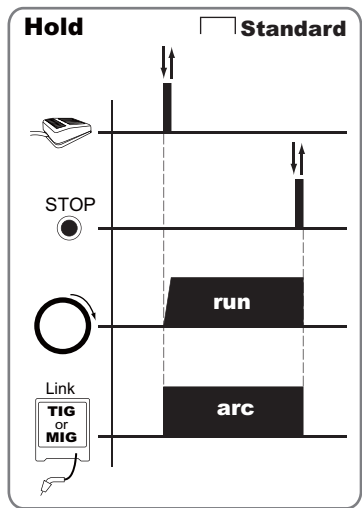

•Adjustable Speed Foot Switch (use the variable speed foot switch) (Option)

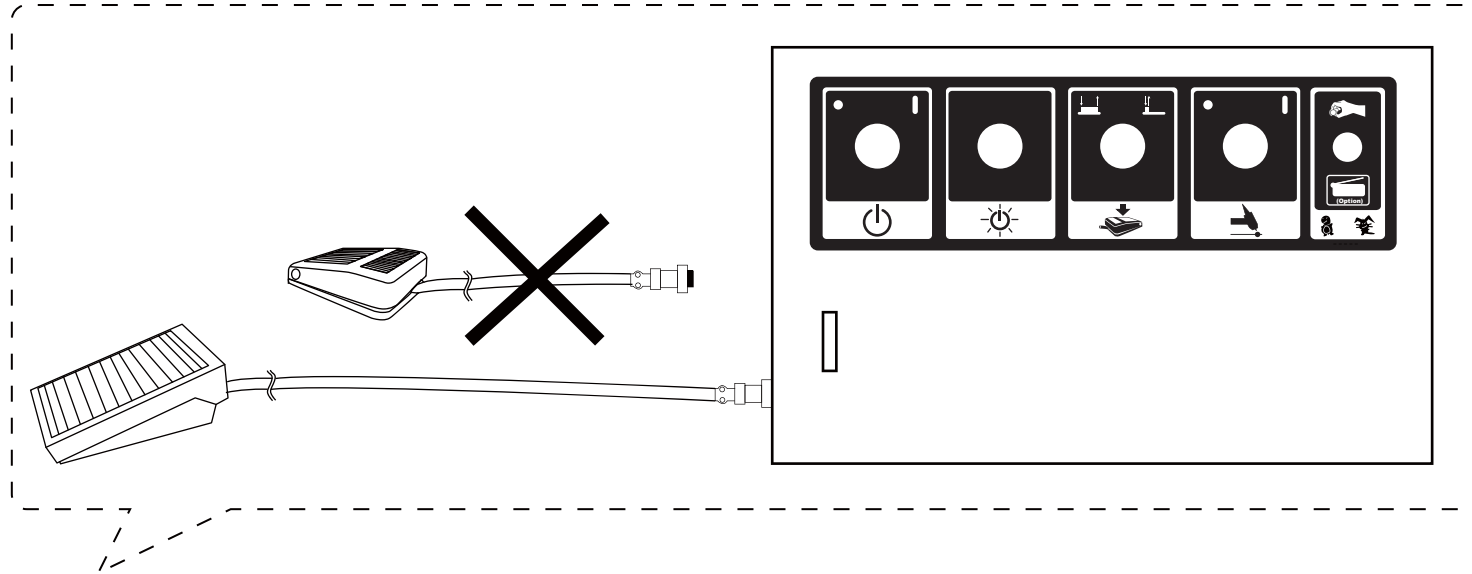
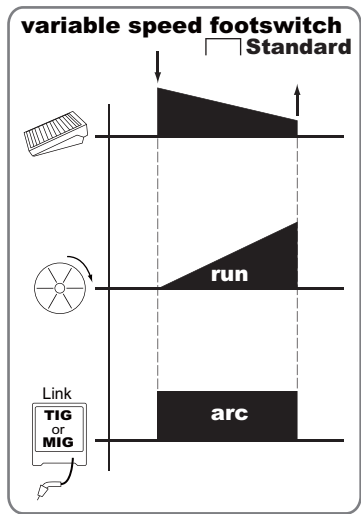

1 •Power switch

2

(Option)

3 •Welder switch

4 •Start switch

5 •Roll and welder on

6 •Increase or lower the pressure

↓

↑

Low

High

•table speed to low or high

7 •switch off

8 •Table and welder off

•Table start and accelerate time to adjust

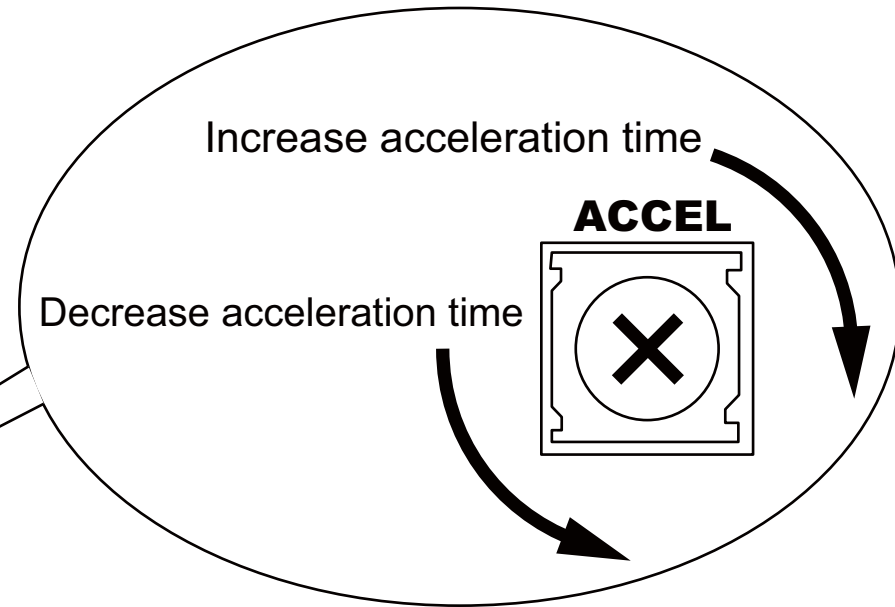
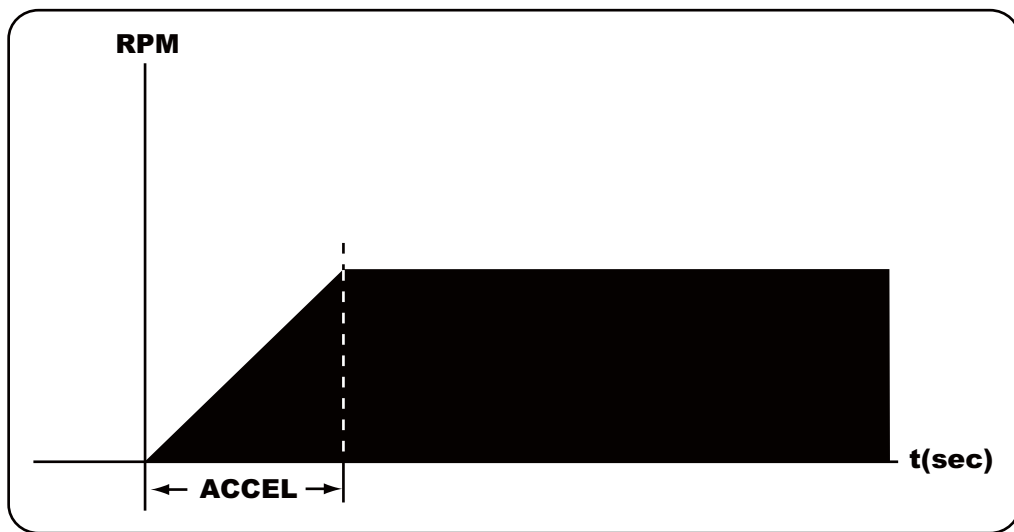

Open the control panel

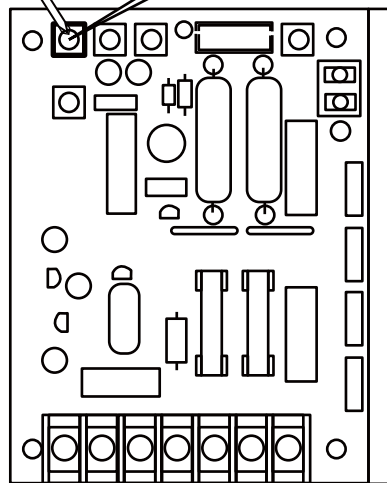
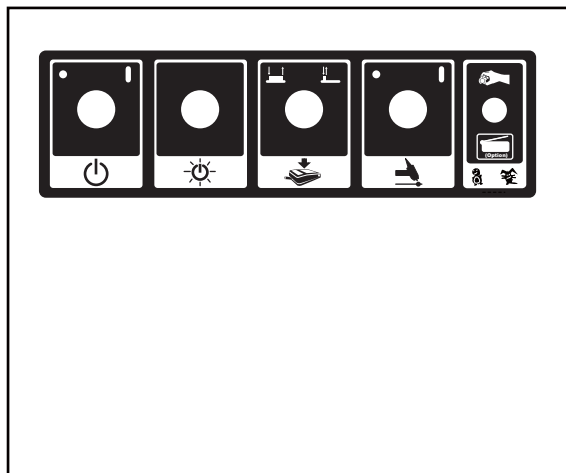

DC motor driver

D25/6pin

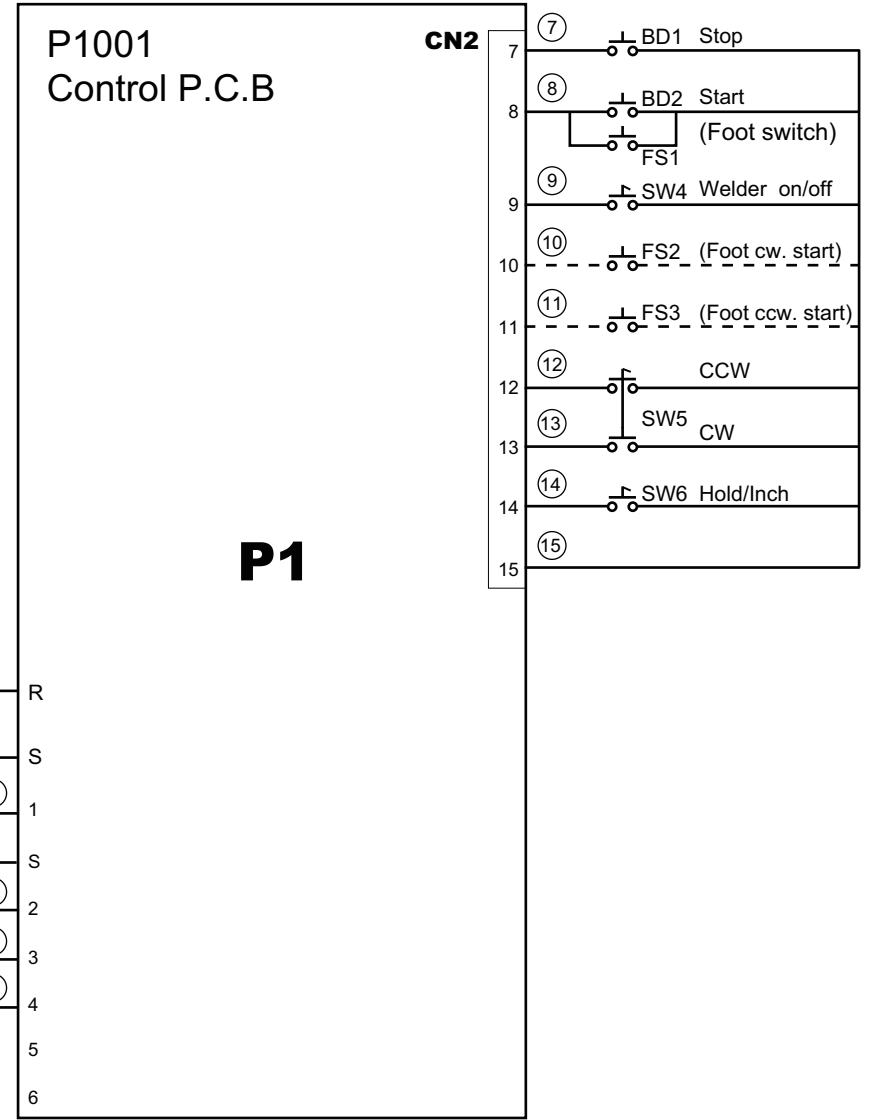
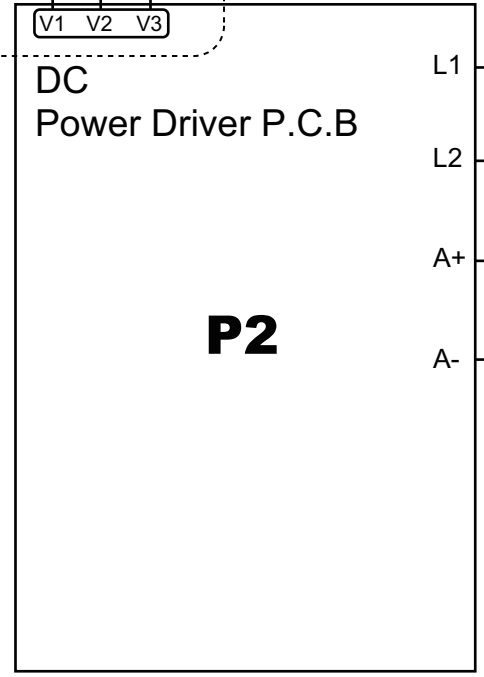
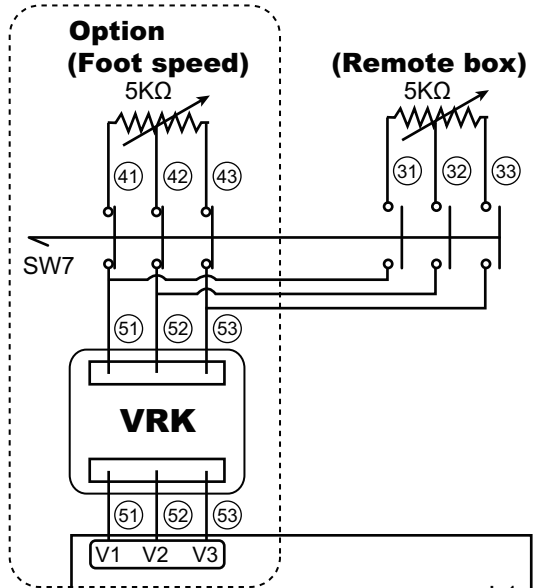
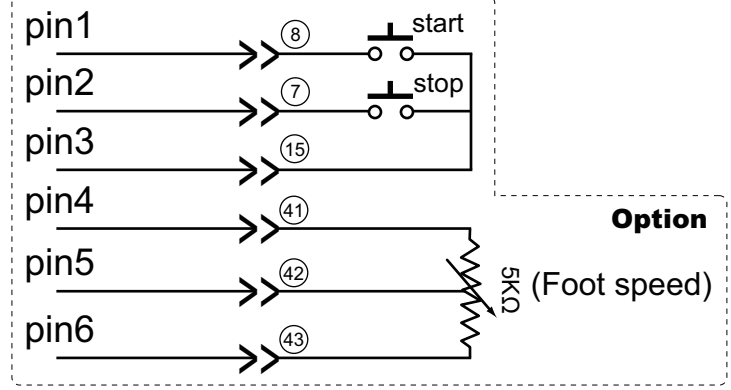

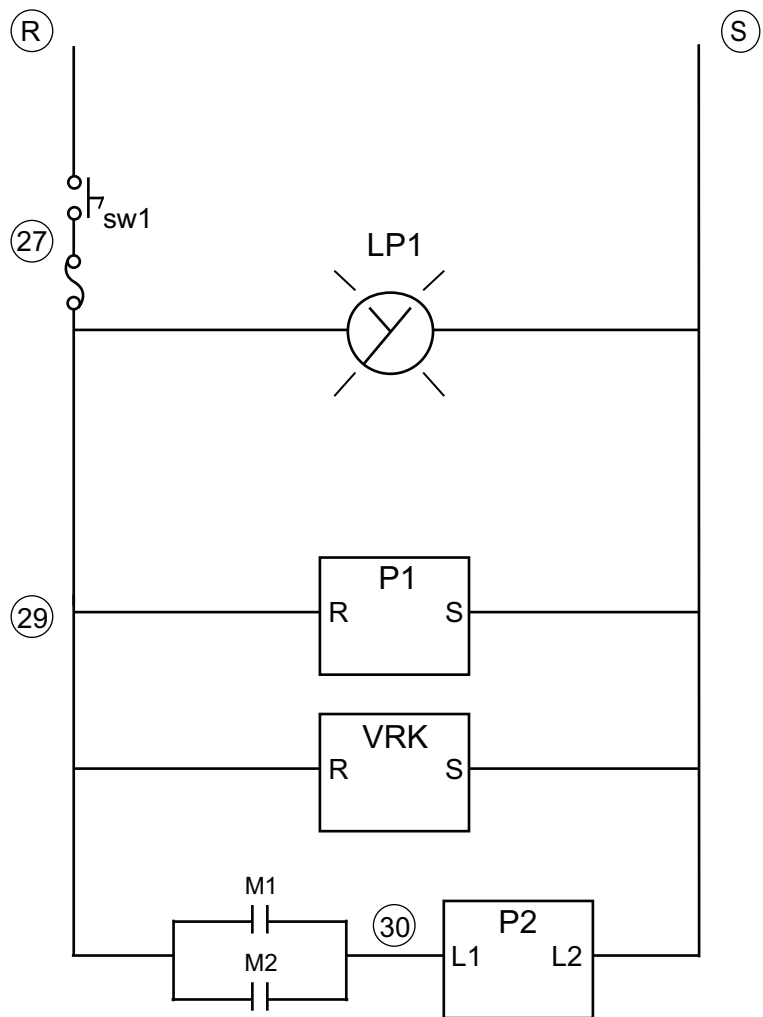

Item	Part No.	Part Name	Q`TY	
P1	P1001	Control P.C.B	1	
P2	DCP-3HPV18A2	DC Power driver P.C.B	1	
M1	CN16/220/3A1B	Table Power Relay	1	
M2	CN16/220/3A1B	Table Power Relay	1	
SW1	SW22(R)	D22 Switch (power)	1	
SW4	SW22(G)	D22 Switch (welder)	1	
SW5	T021	3pin Switch (cw/ccw)	1	
SW6	SW22(B)	D22 Switch (auto/manual)	1	
Option	SW7	SNAP1421	9pin Switch	1
	BD1	RB12(R)	D12 Button (stop)	1
	VR1	PC-VR1	Resistance 5kΩ	1
	FS1	FS-101Z(4M)	Foot Switch(Start)	1
	LP1	LP22R220	D22 Light (Red/220)	1
	DM	DCM400W18V	DC 400W/180V Motor	1
	VRK	VRK01-V2	VR Link P.C.B(AC 230V)	1

SIR-5T
AC230V/1Ø

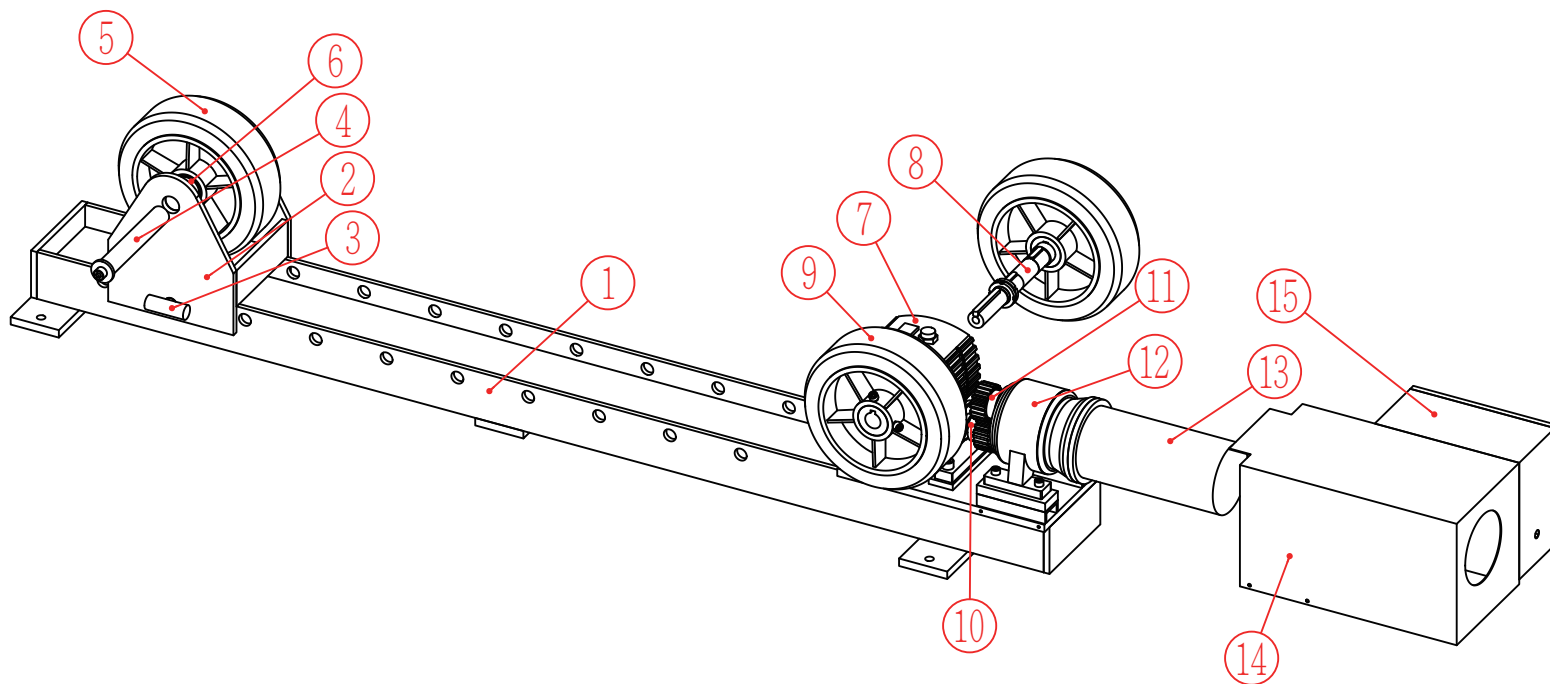

Item	Port Name	Port No.	Q`TY
1.	Roller Base	SIR5T01	1
2.	Idle Shelf	SIR5T03	1
3.	Pin	SIR5T011	1
4.	Idle Axis	SIR5T04	1
5.	Idle	SIR5T09	1
6.	Ring	SIR5T05	2
7.	Worm Gear Reducer	LOW80V-30B	1
8.	Drive Axis	SIR5T10	1
9.	Drive	SIR5T08	2
10.	Drive Gear	SIR5T07	1
11.	Drive Gear	SIR5T06	1
12.	Gear Reducer	CHM-200-1:50	1
13.	DC Motor	PM-V400W180V	1
14.	Motor Cover	SIR5T12	1
15.	Box	SIR5TC	1

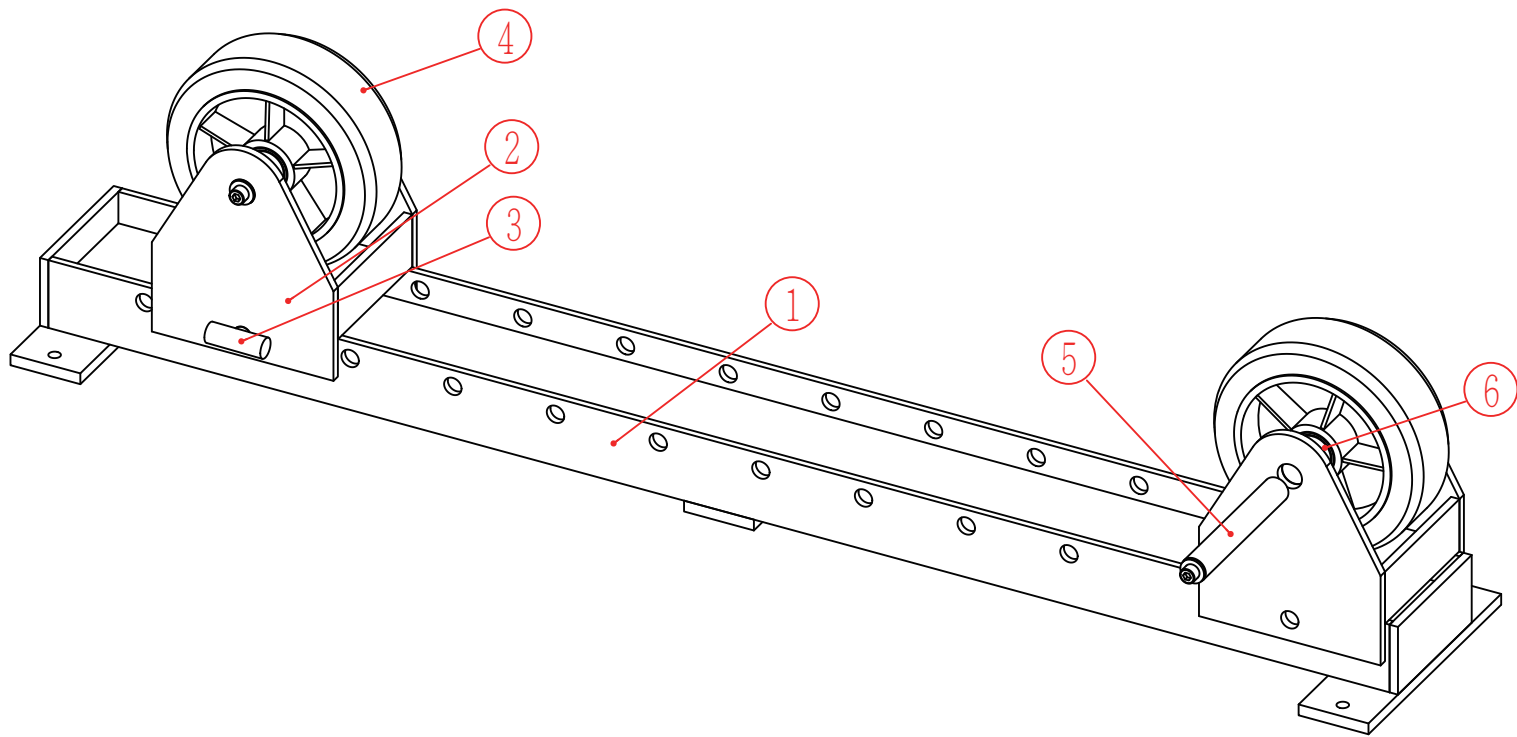

Item	Port Name	Port No.	Q'TY
1.	Roller Base	SIR5T02	1
2.	Idle Shelf	SIR5T03	1
3.	Pin	SIR5T011	1
4.	Idle	SIR5T09	2
5.	Idle Axis	SIR5T04	2
6.	Ring	SIR5T05	4